

LICENSE AGREEMENT

Static Control Components, Inc. (Static Control) grants this limited license to the person, firm or corporation (hereinafter "User") downloading electronically or by printing this file to use Static Control's copyrighted documents in accordance with the terms of this agreement. If you agree with the terms of the license then you may download this information. If you do not agree with the terms of the license, then you are not authorized to use this information, and any use of it may be in violation of Static Control's copyrights or trademarks.

TRADEMARKS

The Static Control material herein may make reference to its own trademarks, or trademarks of others. Static Control grants a limited license to the User to use Static Control's trademarks in its internal documents and for its internal purposes on the following terms and conditions. Any use of Static Control's trademark must be used in a context which makes it clear that the product reference is a Static Control Components, Inc. product, and not a product from any source. The materials provided to the User may include reference to trademarks of others. Any use of the User makes of these marks should reference the owner of those marks. Nothing in this agreement constitutes any authorization by Static Control to use any of these trademarks in any context.

COPYRIGHTS

Static Control grants a limited license to the User to use the attached copyrighted documents. The permitted use of these documents is limited to internal purposes and needs of the company. The company is prohibited from using these copyrighted documents, or any part of them, including graphic elements, in any materials that are used outside the physical business location of the User. The User is prohibited from using any materials in any documents whether printed or electronic, which are distributed to any third party. The use of these copyrighted documents, or parts of them, including graphic elements, from these documents in marketing material, either print, electronic or web is prohibited. The sale, transfer, copying of these documents or any parts of these documents to any other party is prohibited.

Static Control Components, Inc. retains all rights to its copyrighted documents, and any use of these documents by User should reference Static Control's copyrights, with the notice "copyright Static Control Components, Inc."

Static Control reserves the right to cancel this license on 30-days written notice. All of the User's material incorporating Static Control's copyrighted documents shall be destroyed upon receipt of its notice of termination.

The User may not distribute, share, and otherwise convey the copyrighted documents to any other persons, corporations or individuals.

The User, by use of these documents, acknowledges Static Control's copyright in these materials.

STATIC CONTROL DOES NOT GUARANTEE OR WARRANT DOWNLOADED INFORMATION

The information User is downloading is published by Static Control in "as is" condition "with all faults". Static Control makes no representations or warranties of any kind concerning the quality, safety, or suitability of the downloadable materials, either express or implied, including without limitation any implied warranties of merchantability, fitness for a particular purpose, or non-infringement. Further, Static Control makes no representations or warranties as to the truth, accuracy or completeness of any statements, information or materials concerning items available for download. In no event will Static Control be liable for any indirect, punitive, special, incidental, or consequential damages however they may arise even if Static Control has been previously advised of the possibility of such damages.



Version 2 -July 2005
SYSTEM SUPPORT SERIES™

CARTRIDGE REMANUFACTURING
INSTRUCTIONS FOR:

**SAMSUNG® ML-2250;
SCX-4720; XEROX®
PHASER 3150;
WORKCENTRE PE120
AND THE DELL® 1600**

TABLE OF CONTENTS

Introduction	i
Needed Tools & Supplies	ii
Printer Specifications	iii
Wireline	iv
Separating the Cover	.1
Disassembling the Developer Unit	.2
Reassembling the Developer Unit	.4
Replacing the Cover and filling with Toner	.8

GO TO WWW.SCC-INC.COM

For the latest cartridge information
Click on "Online Engine Center"

Other System Support Series™
documents available in
Adobe® Acrobat® format

QUESTIONS?

Please call one of our main numbers
and ask for your
Support Team Representative
or E-mail us at:

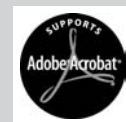

US AND CANADA
info@scc-inc.com

UK
info@scceurope.co.uk



Samsung® 2250

Reference Info

The Samsung® ML-2250 was released in July 2004 and was targeted at home users and small business workgroup applications. There are four models of the ML-2250; the base ML-2250 model, the 2251N which is the same as the base model but it is network ready with no postscript option. The 2251NP is the same as the 2251N except it has the postscript option. The last model is the 2252W, which is the same as the 2251NP with wireless connectivity. Each printer ships with a 5,000 page standard cartridge.

Use of Compressed Air

As of April 28, 1971, the Occupational Safety & Health Administration (OSHA) Standard, 29 CFR 1910.242 paragraphs a & b for general industry requires effective chip guarding and personal protective equipment (PPE) when using compressed air. When cleaning residual toner particles from cartridges using a compressed air system, you must use air nozzles meeting OSHA requirements. Air nozzles that regulate air pressure to a maximum of 30 psi comply with this standard. Refer to the OSHA publication for any updates or changes that have occurred since the date noted above.

Use of Isopropyl Alcohol

For best results 91-99% Isopropyl Alcohol should be used for cleaning as directed in this instruction. 91% Isopropyl Alcohol is available at most major drug stores; 99% Isopropyl Alcohol is available through distributors of chemical products. Follow the Alcohol manufacturer's safety instructions.

WWW.SCC-INC.COM

US AND CANADA 800.488.2426 • INTERNATIONAL 919.774.3808 • EUROPE +44 (0) 118.923.8800

US/CAN FAX: 800-488-2452 • INTERNATIONAL FAX 919-774-1287



Purpose of this SSS

The purpose of this SSS is to provide you a guide and the basic information needed to remanufacture a Samsung® ML-2250, SCX-4720, Xerox® Phaser 3150 and WorkCentre PE120, and the Dell® 1600. This SSS contains information about:

- Disassembling each section.
- Basic cleaning.
- Reassembling the cartridge.

Your cartridge might have been changed by the original equipment manufacturer (OEM) and include parts or features which are not described in this documentation. The documentation might be updated occasionally to include information about those changes, or technical updates might be available from the SCC Web site. Complete the following steps to check for updated documentation and technical updates:

Before you begin, read the entire SSS to familiarize yourself with the procedures and take notes.

Be sure to follow all necessary safety precautions while working with tools, and chemicals, such as toner and alcohol.

Illustrations

The illustrations and photos in this document might differ slightly from your cartridge. Every effort is made to include the most up to date photos and illustrations at the time of printing. However, the OEM may make changes which were not available at the time of printing.

Safety

Statement 1:



Always wear eye protection while operating power tools.

Statement 2:



Always wear eye protection and protective clothing while working with toner and or other chemicals.

Statement 3:



Do not swallow or ingest toner, isopropyl alcohol, toner dust, or any chemicals or materials used in the process of remanufacturing

Needed Tools & Supplies

For Basic Remanufacturing:

- Phillips Screwdriver
- Needle nose Pliers
- Compressed Air for Cleaning
- 91%-99% Isopropyl Alcohol
- Lint-Free Foam Tip Swab (LFSWAB)
- Lint-Free Cleaning Cloth (LFCLOTH)
- Small Flatblade Screwdriver
- Felt Foam Scraper (FSTOOL)
- Blade Installation Tool (IBMSBTOOL)

The following table is a summary of the Samsung® 2250 printer specifications. This information was obtained from the OEM's web site and is considered to be the most up to date information at the time of printing.

Printer Information	Samsung® 2250
Printer Introduction Price	\$229
Processor	166 MHz
First page	10 seconds
Memory	16 MB to 144 MB
Duplex	Manual
Engine Information	
Print Resolution (dpi)	1200/1200
Print Speed (pages per minute)	22 ppm
Duty Cycle (pages per month)	30,000

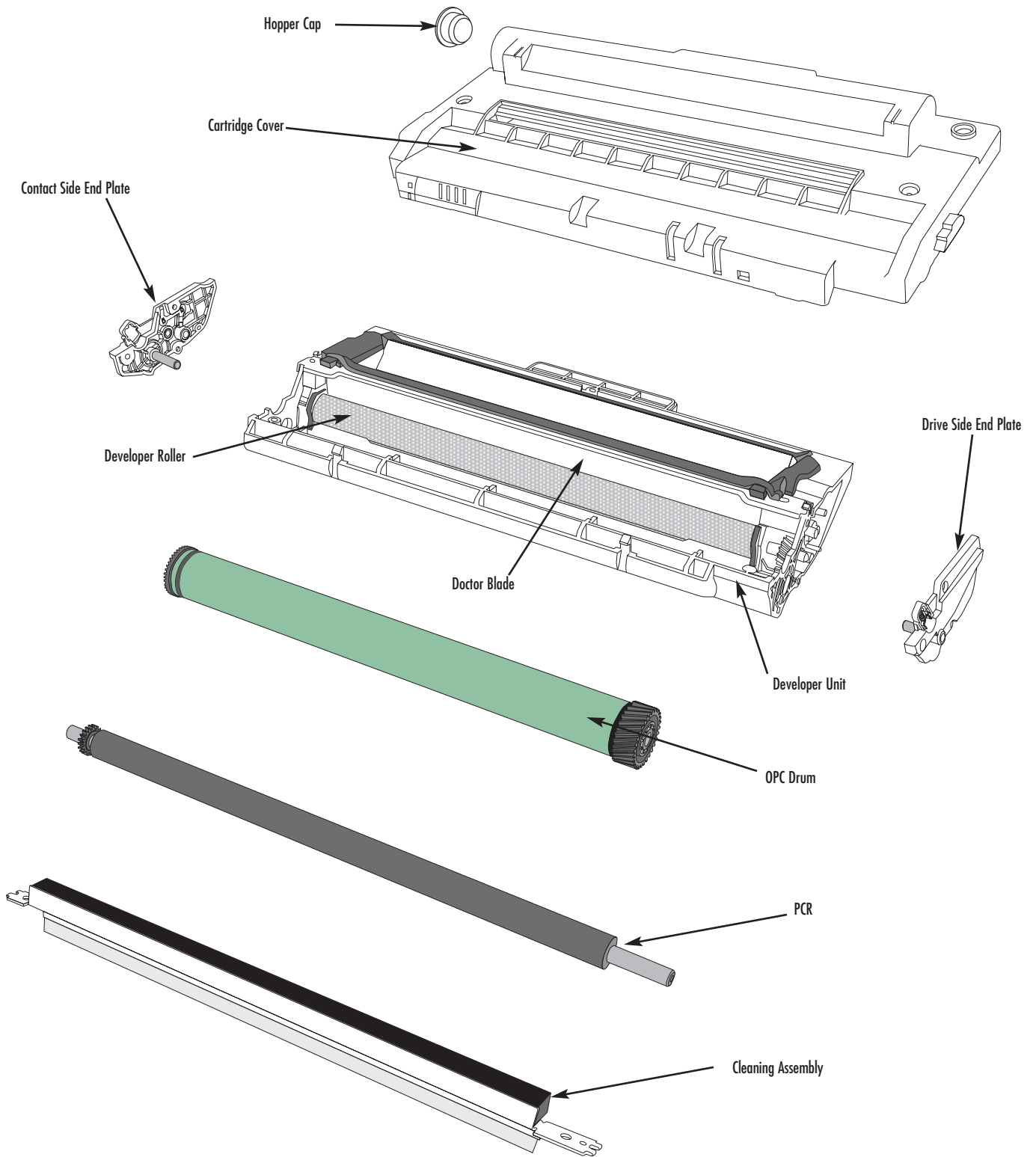

Developer Unit Assembly
product wirelines



Separating the Cover from the Developer Unit

REMANUFACTURING THE **SAMSUNG® 2250/4720**, **XEROX® PHASER 3150/ PE120**
AND THE DELL® 1600

This section provides the information needed to separate the Cover from the Developer Unit. Before attempting to perform the following procedures, read the entire section carefully. Ensure that you follow all necessary safety precautions.

1. Remove the five screws from the top of the cartridge, as shown in Figure 1.

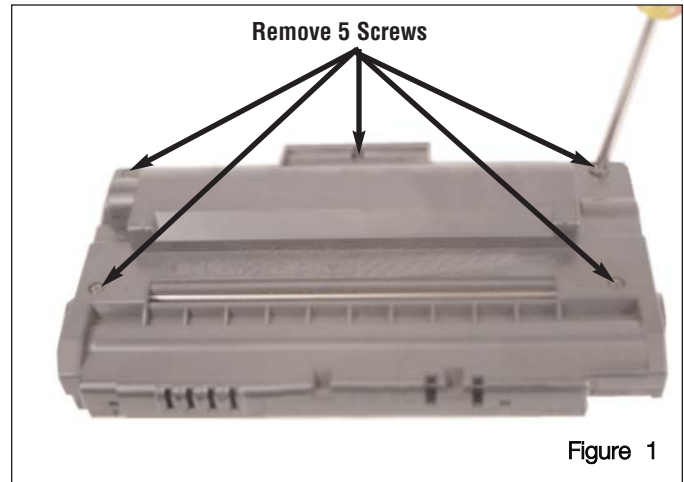

Remove the five screws from the top of the cartridge.

2. Using a small flatblade screwdriver release the four clips (two in the front and two in the back) that secure the two sections together, as shown in Figure 2a and 2b.



Release the four clips that secure the two sections together

3. Remove the top of the cartridge, be careful not to spill the remaining toner from the cartridge; As shown in Figure 3.



Lift off the top of the cartridge.



Disassembling the Developer Unit

REMANUFACTURING THE **SAMSUNG® 2250/4720, XEROX® PHASER 3150/ PE120 AND THE DELL® 1600**

This section provides the information needed to disassemble the Developer Unit of the cartridge. At this point you should have separated the cover from the Developer Unit as described earlier in this SSS™. For information on separating the two sections see "Separating the Cover from the Developer Unit" on page 1. Before attempting to perform the following procedures, read the entire section carefully. Ensure that you follow all necessary safety precautions.



Note: Dump remaining toner from the Developer Unit before continuing the remanufacturing process.

1. Remove the Contact Side End Plate.
 - a. Using a phillips screwdriver, remove the four screws from the Contact Side End Plate, see Figure 4.
 - b. Remove the Contact Side End Plate from the cartridge.

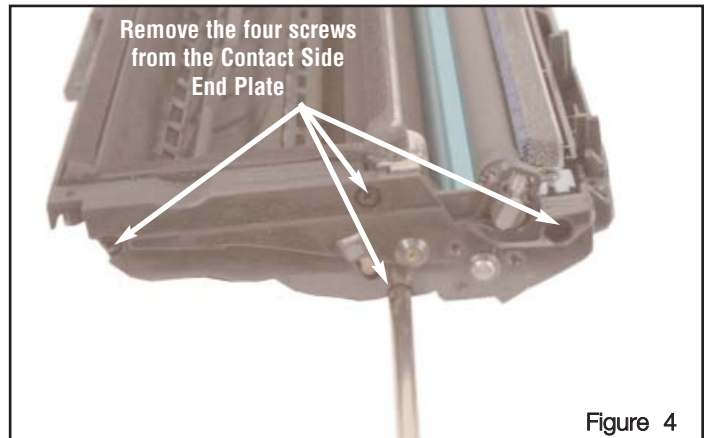

Figure 4

Using a phillips screwdriver remove the four screws in the Contact End Plate.

2. Remove the Drive Side End Plate.
 - a. Using a phillips screwdriver, remove the four screws from the Drive Side End Plate.
 - b. Remove the Drive Side End Plate from the cartridge.

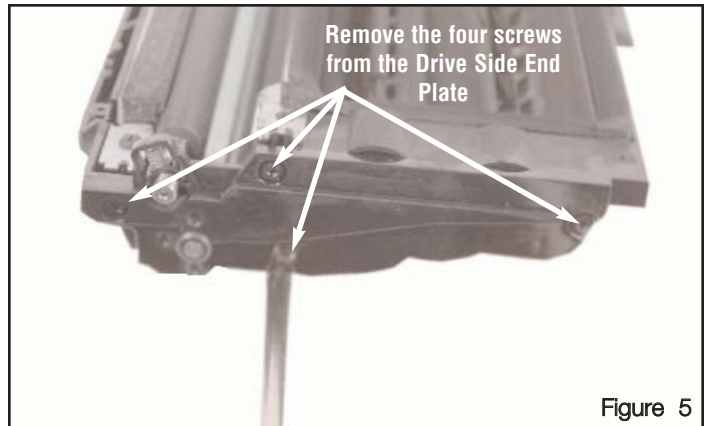

Figure 5

Using a phillips screwdriver remove the four screws in the Drive Side End Plate.

3. Grasp the PCR by the metal shafts. Lift out of the cartridge and place on a dry, lint free cloth; see Figure 6. Clean with a dry, lint free cloth dampened with water.

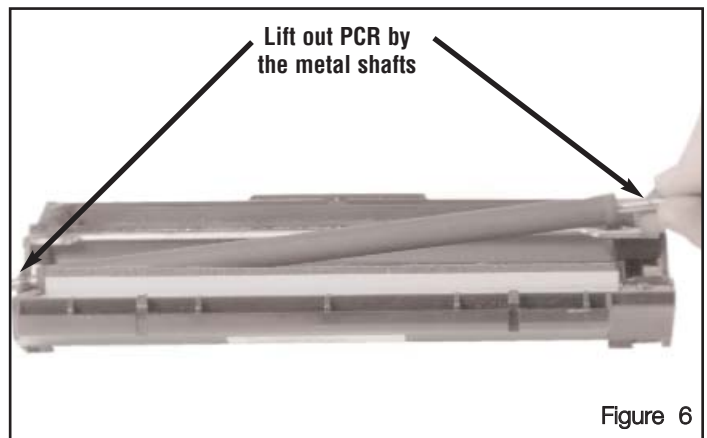
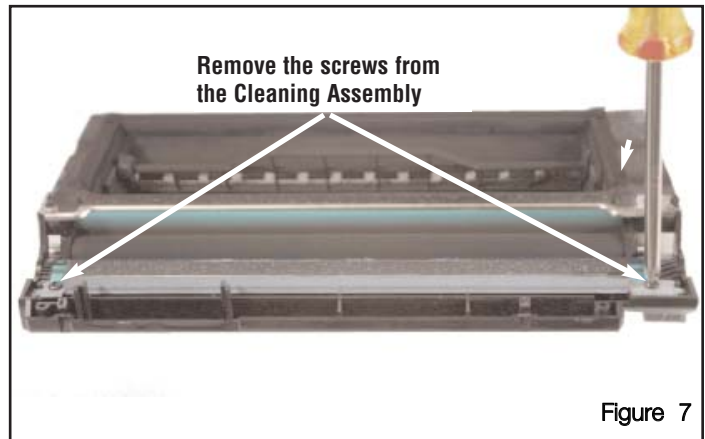

Figure 6

Remove the PCR from the cartridge.

Disassembling the Developer Unit

- Remove the two phillips screws from the Cleaning Assembly; then, lift the Cleaning Assembly from the cartridge by the metal ends, see Figure 7. Fluff the Cleaning Assembly with dry filtered compressed air.



Remove the two phillips screws from the Cleaning Assembly, then remove from the cartridge.

- Grasp the Drum by the gears, and lift out of the cartridge as shown in Figure 8.



Lift the Drum from the Developer Unit

- There are seven gears under the Drive Side End Plate, see Figure 9. Remove each gear from the Developer Unit.

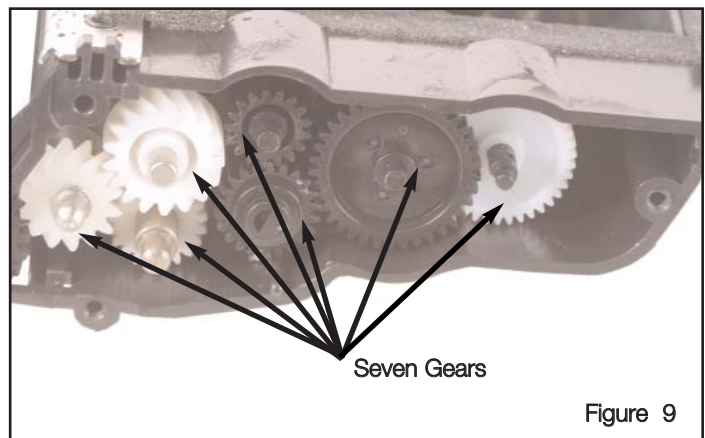

Remove the seven gears from the drive side.

Disassembling the Developer Unit

7. There are two washers under the gears, note the location of each washer and remove from the Developer Unit, see Figure 10.

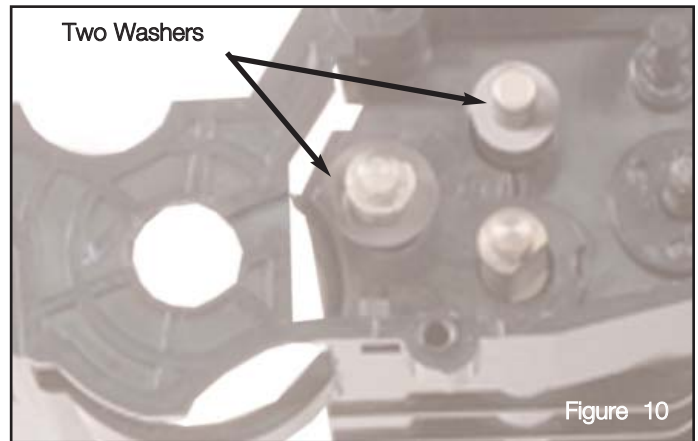

Remove the two washers from the drive side.

8. Clean the Developer Unit and the End Plates with dry, filtered compressed air as shown in Figure 11.

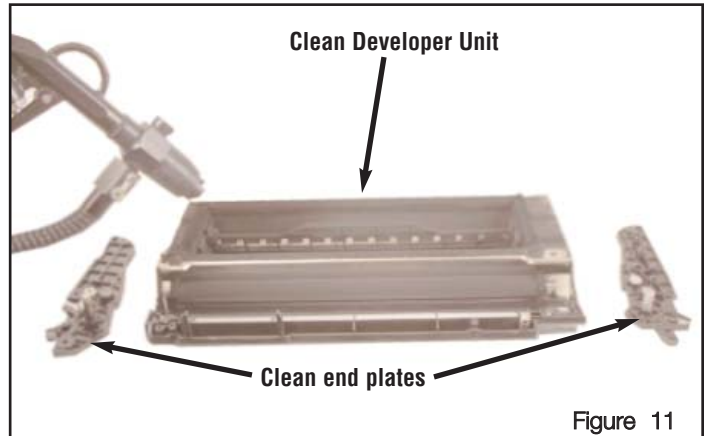

Clean the Developer Unit and End Plates with dry, filtered compressed air.

9. Remove the Drive Side Developer Roller Plate and the Developer Roller.
 - a. Using a small flat blade screwdriver release the bottom tab on the Developer Roller Plate, as shown in Figure 12.

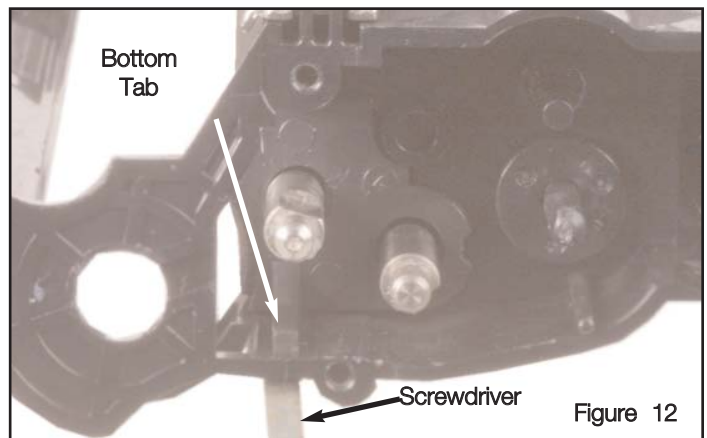

Release the bottom tab of the Developer Roller Plate.

Disassembling the Developer Unit

- b. Using a flat blade screwdriver release the tab on the top of the Developer Roller Plate. See Figure 13 for tab placement.



Release the top tab of the Developer Roller Plate.

- c. Grasp the metal shaft of the Developer Roller and slide the Developer Roller and the plate out of the Developer Unit, as shown in Figure 14.



Note: Be sure not to lose the teflon and mylar washers on each end of the Developer Roller if replacing the Developer Roller.

Clean the Adder Roller with dry, filtered compressed air.

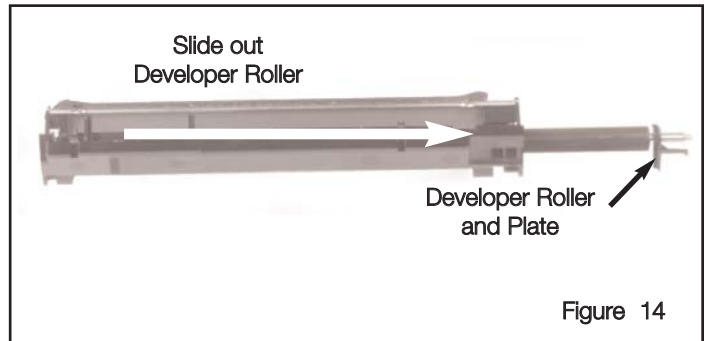

Slide out the Developer Roller and the Developer Roller Plate.

10. Inspect the Developer Roller Sealing Blade for wear, rips, waves, or kinks. If the Developer Roller Sealing Blade is damaged it will need to be replaced.

11. Remove the Developer Roller Sealing Blade. Using needlenose pliers slowly peel the Developer Roller Sealing Blade from the Developer Unit, as shown in Figure 15.

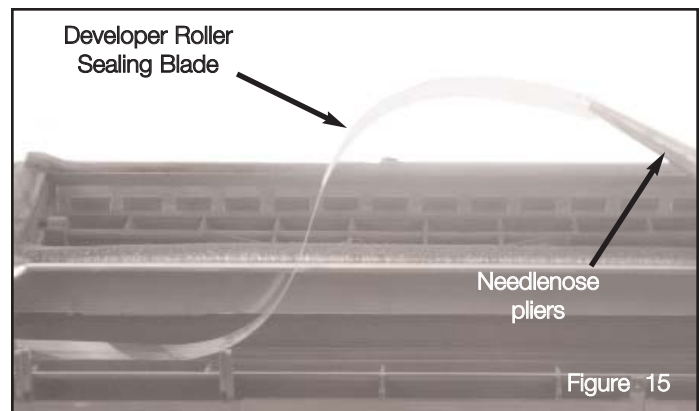

Peel away the damaged Developer Roller Sealing Blade.

For instructions on replacing the Doctor Blade, the Felts, and the Foams, please refer to SSS™ # 760.



Reassembling the Developer Unit

REMANUFACTURING THE **SAMSUNG® 2250/4720, XEROX® PHASER 3150/ PE120 AND THE DELL® 1600**

1. Using a cotton swab, clean the End Plates with 91-99% Isopropyl alcohol as shown in Figure 16.

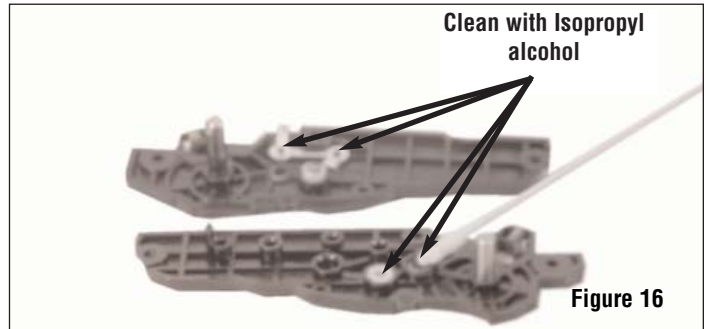

Clean PCR saddles and contacts with Isopropyl Alcohol.

2. Using a cotton swab, apply contact grease to the Drum, Adder Roller, and Developer Roller contacts; as well as the PCR saddle, see Figure 17.

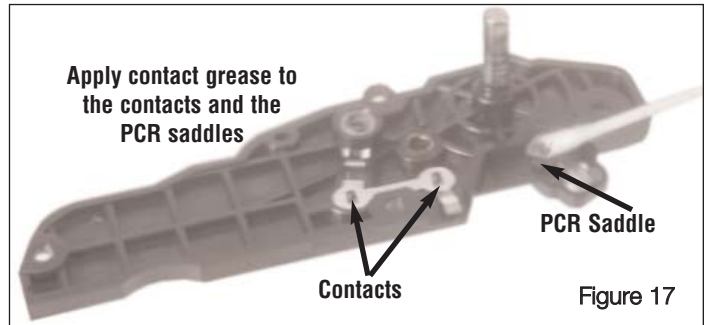

Apply contact grease to the End Plate contacts and PCR saddles.

3. Clean the Developer Roller Sealing Blade mounting surface with a cotton swab dampened with 91-99% Isopropyl alcohol. Install the new Developer Roller Sealing Blade using the IBMSBTOOL (For information on how to use the IBMSBTOOL please refer to SSS™ # 605). Align the edges of the Developer Roller Sealing Blade with the edges of the mounting surface, as shown in Figures 18a & 18b.



Note: It may be easier to install the Sealing Blade with the Doctor Blade removed from the Developer Unit. For information on how to remove the Doctor Blade please refer to SSS™ #760 for complete instructions on replacing the Doctor Blade and the Felts and Foams.

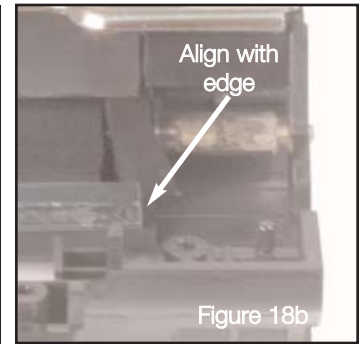
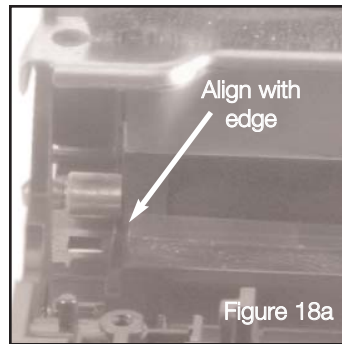

Install the new Developer Roller Sealing Blade.

4. Attach the Developer Roller Plate to the Developer Roller and slide into the Developer Unit as shown in Figure 19a. Secure the Developer roller Plate by ensuring that the tabs on the top and bottom snap in to place, see Figure 19b.

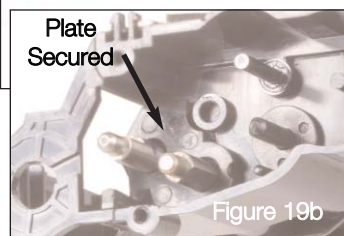
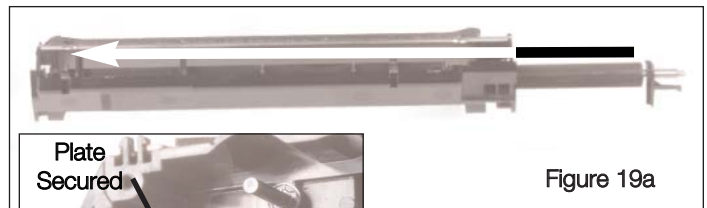

Reassembling the Developer Unit

4. Install the two washers in to place, as shown in Figure 20a, and apply Lubriplate # 105 to the gear shafts. Install the seven gears in to the drive side in the order shown in Figure 20b.

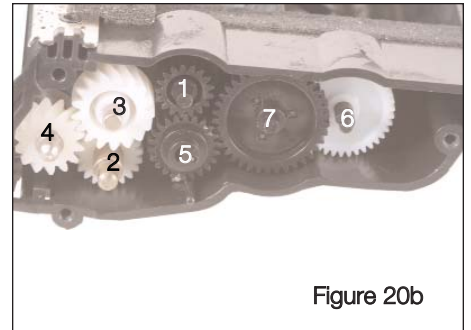
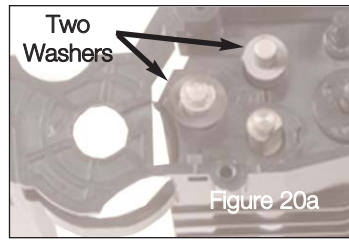

5. Grasping the Drum by the gears, gently place the drum into the Developer Unit, as shown in Figure 21.

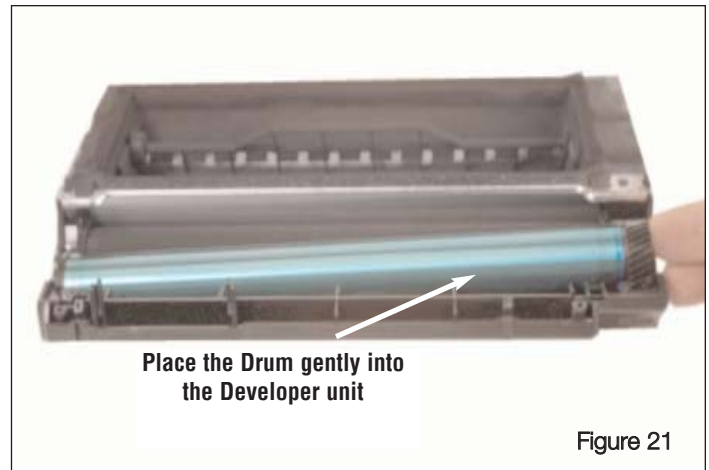

Place the drum into the Developer Unit

Reassembling the Developer Unit

4. Install the Cleaning Assembly, by attaching the two phillips screws, see Figure 22.



Install the Cleaning Assembly.

5. Grasp the PCR by the metal shafts and place into the Developer Unit, as shown in Figure 23.

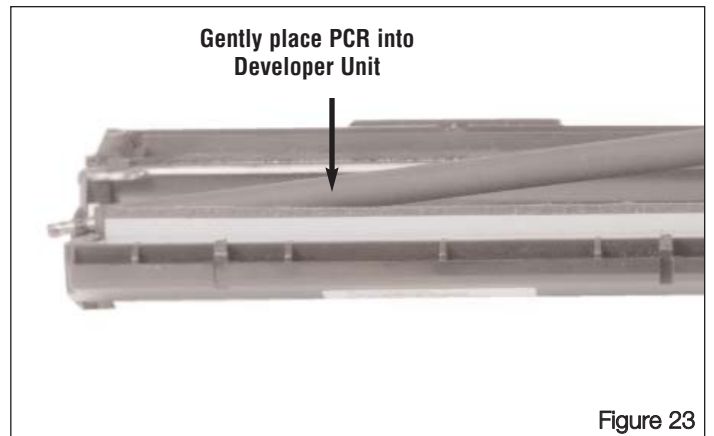

Place the PCR into the Developer Unit.

6. Attach the Drive Side End Plate, to the Developer Unit and secure with four phillips screws, as shown in Figure 24.

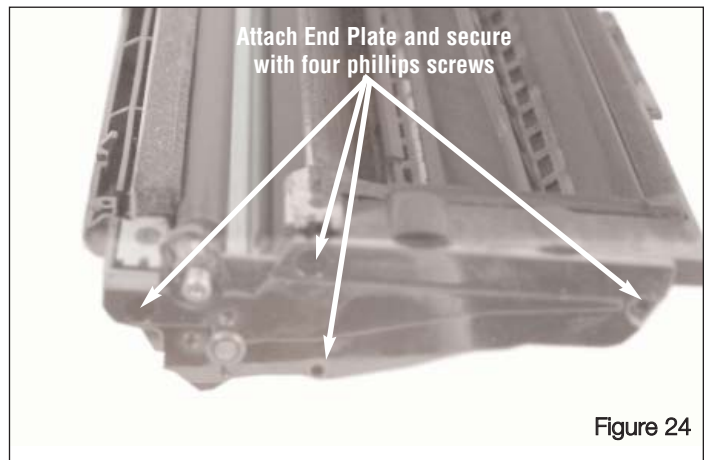

Attach the Drive Side End Plate to the Developer Unit.

Reassembling the Developer Unit

7. Attach the Contact Side End Plate, and secure with four phillips screws as shown in Figure 25.

8. For chip solution, please refer to SSS# 693.

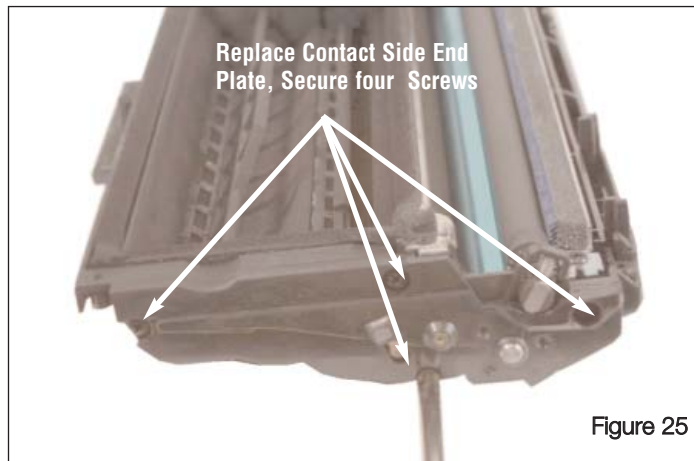

Attach the contact side end plate, and secure with four screws



Replacing the Cover

REMANUFACTURING THE **SAMSUNG® 2250/4720, XEROX® PHASER 3150/ PE120 AND THE DELL® 1600**

1. Push the Hopper cap out of the cover before attaching the cover to the Developer Unit.
2. Place the cover of the cartridge onto the Developer Unit and secure with the five phillips screws, see Figure 26. Be sure that each clip is latched before screws are installed.

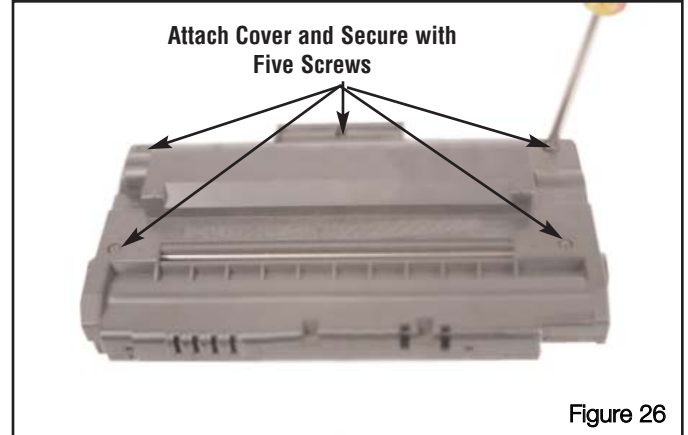

Replace the cover onto the Developer Unit.

3. Fill the cartridge with toner, as shown in Figure 27.

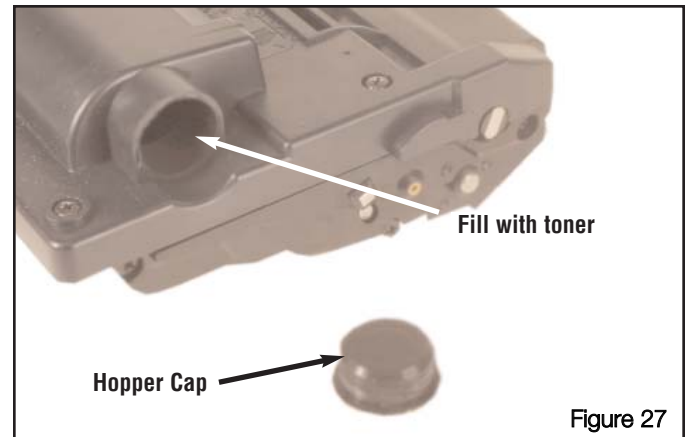

Fill cartridge with toner and install the hopper cap.



STATIC CONTROL COMPONENTS, INC.

MOVING AT THE SPEED OF NEW TECHNOLOGY

The development of cartridge imaging systems is the primary mission of our Imaging Labs. Through extensive testing and research, we develop the optimum combination of matched components for each cartridge system. Our engineering and manufacturing expertise provides us with total control in design, quality and development to produce products from the ground up. The result is a system of components that seamlessly work together in each cartridge application.

This dedication and commitment results in integrated cartridge systems that Static Control fully supports, allowing you to quickly attack new market opportunities with complete confidence in the reliability and performance of your cartridges.



STATIC CONTROL COMPONENTS, INC.

SCC Imaging Division

3010 Lee Avenue • PO Box 152 • Sanford, NC 27331
US/Can 800-488-2426 • US/Can Fax 800-488-2452
Int'l 919-774-3808 • Int'l Fax 919-774-1287
www.scc-inc.com

Static Control Components (Europe) Limited

Unit 32, Sutton's Business Park • Sutton's Park Avenue •
Earley Reading • Berkshire RG6 1AZ • United Kingdom
Tel +44 (0) 118 935 1888 • Fax +44 (0) 118 935 1177